

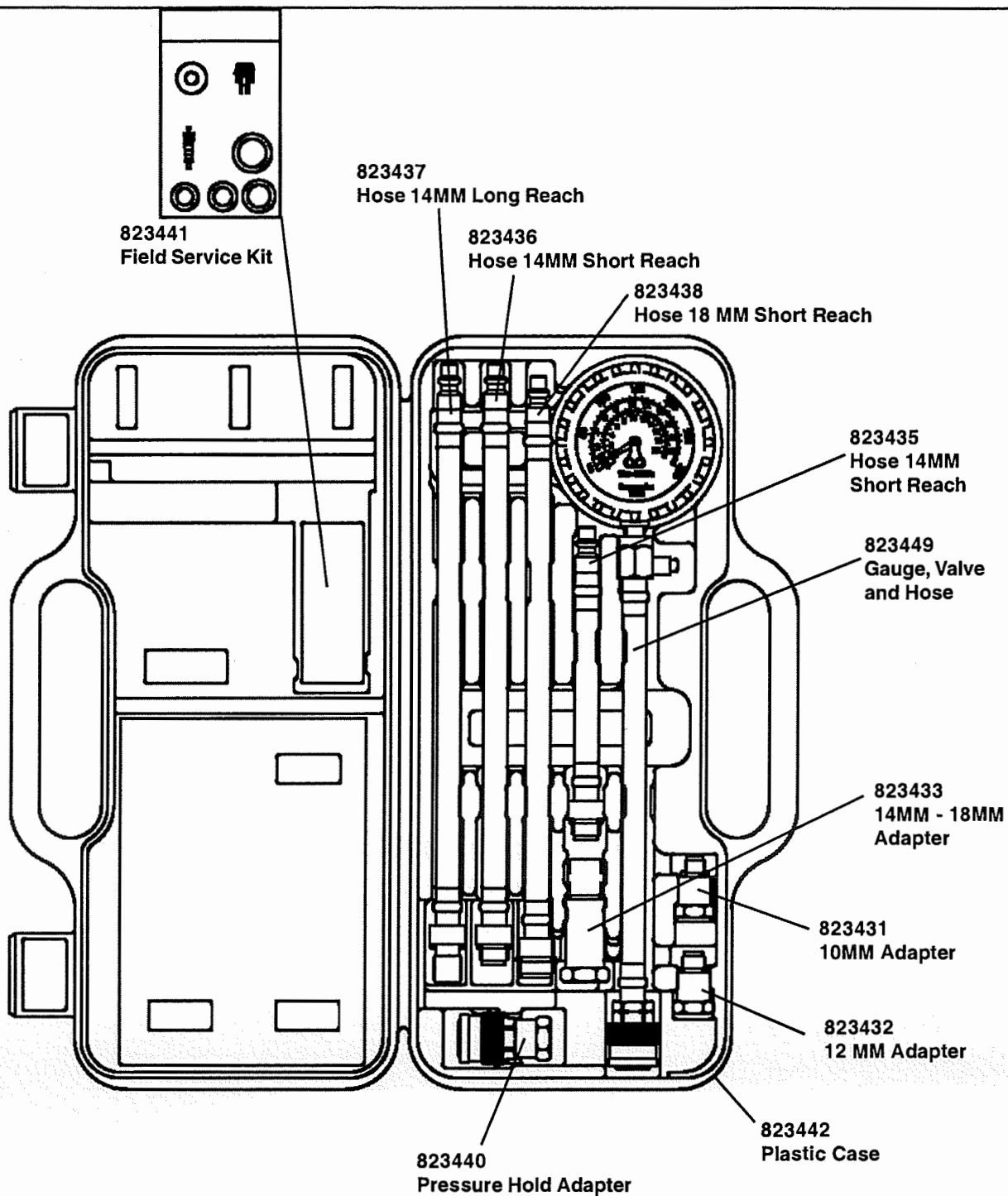

MODEL 47089
COMPRESSION TEST KIT





Part No.	Description	Part No.	Description
823431	10MM Adapter	823438	Hose Long reach 18MM x 11.625
823432	12MM Adapter	823440	Pressure Hold Adapter
823433	14MM Female - 18MM Male Adapter	823441	Field Service Kit
823435	Hose Short Reach 14MM x 6.05	823442	Case
823436	Hose Short Reach 14MM x 11.625	823448*	Gauge
823437	Hose Long Reach 14MM x 11.951	823449	Gauge Assembly

* Not Shown

Included in this Kit

- Heavy duty 2 3/4" (70 mm) gauge with high impact lens, rubber boot, and three (3) scales of measure (psi, kg/cm², bar), attached to 10" (250 mm) hose and quick release coupler
- Four (4) extension hoses:
 - 6 1/2" (165 mm) long x 14 mm thread, short
 - 12" (305 mm) long x 14 mm thread, short
 - 12" (305 mm) long x 14 mm thread, long
 - 12" (305 mm) long x 18 mm thread, short
- One (1) adapter: 14 mm thread, short x 18 mm thread, long
- Two (2) small engine adapters
 - 10 mm thread
 - 12 mm thread
- One (1) quick release air hold adapter
- Custom blow-molded case
- Field service kit

Applications

The Craftsman Professional Compression Test Kit can perform dry or wet compression tests to determine the amount of pressure produced in the cylinder of an engine. It can also be used as a tool for pressurizing an engine cylinder to hold the valves closed while performing repairs.

How to Perform a Compression Test

Precautions & Diagnostic Notes:

WARNING: DO NOT use the ignition switch during the compression test on fuel-injected vehicles. Use of a remote starter switch to crank the engine is recommended. Fuel injectors on many late model vehicles are triggered by the ignition switch during the cranking mode, this could result in a fire hazard or contamination of the engine's oil with fuel.

Always use eye protection when performing compression tests.

An engine in good operating condition will produce a certain amount of pressure in each cylinder. Normally, the cylinders should be within 10 percentage points of one another and within the manufacturer's specifications. The pressure should rise smoothly on each stroke of the engine, until it reaches a peak.

If the pressure reading fails to rise, or it remains the same for several strokes of the engine and begins to rise, the likely cause of the problem is a sticking valve.

If two adjacent cylinders show pressure readings of 20 or more pounds below the other cylinder readings, suspect a blown head gasket.

If a cylinder shows a pressure reading of 15 or more pounds higher than the other cylinders, the probable cause is carbon build-up inside the cylinder.

The Craftsman Professional Compression Test Kit can perform two tests: the dry compression test and the wet compression test. The result of performing these tests will provide an indication of the condition of the piston rings, the cylinders, and valve-train.

Dry Compression Test Procedures:

1. Refer to the appropriate service manual for the compression specifications specific to the engine you are testing.
2. Start engine and allow engine to run until it reaches normal operating temperature (usually about 15 minutes.) Turn engine OFF.
3. Install an auxiliary starter switch in the starting circuit.
4. While wearing eye protection, use compressed air to carefully remove dirt and debris from the area around the spark plugs.
5. Remove spark plugs one at a time, marking the number of the cylinder they were removed from, and place them on a clean flat surface. This will aid you in identifying problem cylinders by allowing the comparison of spark plug appearance to the compression level of a given cylinder.

NOTE: When testing engines with two spark plugs per cylinder, it is only necessary to remove the spark plugs located on the exhaust side.

6. On vehicles with standard distributors, disconnect the coil wire (high tension lead) from the distributor cap and secure it to a suitable ground, or disable the ignition by disconnecting the positive (BAT) terminal from the ignition coil.
7. On vehicles with a distributorless ignition (DIS), disable the ignition system by removing the electronic ignition (control) module fuse, or disconnect the crank angle sensor.

NOTE: Refer to the appropriate service manual to determine which fuse or component to temporarily remove or disconnect.

8. Remove air cleaner from carburetor or throttle body and secure throttle linkage in wide-open throttle (WOT) position.

NOTE: NEVER place anything inside the throttle body; internal damage to the engine could result. On vehicles equipped with port fuel injection, remove throttle linkage covers (as necessary) and secure throttle linkage in the wide-open throttle (WOT) position.

9. Crank engine several times to ensure removal of any foreign matter that may have fallen into the cylinders during preparation for test.
10. Select the appropriate adapter fitting (14mm, 18mm short reach or 14mm, 18mm long-reach), and thread adapter into spark plug hole of cylinder head.
11. Connect the appropriate test hose or adapter to the gauge assembly.
12. Crank the engine at least five compression strokes or until the pressure reading stops increasing on gauge.
13. Read the pressure level on the gauge and record the reading along with the cylinder number being tested. **Example: #1-150 psi, #2-145 psi, etc.**
14. Repeat this test on each cylinder. If any of the cylinder readings are found to be low or uneven, perform wet compression test.

15. When compression test is complete, return the spark plugs to their respective cylinders and the throttle and ignition components to their normal positions.

Wet Compression Test Procedure

CAUTION: DO NOT perform the wet compression test on any diesel engine. The higher compression in a diesel engine may cause engine damage or injury to the technician.

The wet compression is a way to remove the influence of the piston rings, pistons and cylinders from the compression test. After completing the dry compression test, squirt approximately one teaspoon of engine oil into the spark plug holes and crank the engine several times to seal the piston rings. Repeat the dry compression test outlined above. **NOTE: If the readings during the wet compression test are greater, then air is leaking around worn or damaged piston rings. If the reading is approximately the same for both wet and dry tests then the valves, valve lifters or the camshaft lobes are worn. Any low reading of cylinder compression indicates worn or damaged parts.**

Small Engine Compression Testing

The **Craftsman** Professional Compression Test Kit has two (2) adapters, 10mm and 12mm, that allow it to be used on small engines found in lawn mowers, chain saws and line trimmers. To use these adapters:

1. Disconnect the spark plug wire and remove the spark plug.
2. Thread the appropriate size adapter onto the compression tester main hose end until the o-ring seats (do not use a wrench to tighten).
3. Thread the assembly into the cylinder spark plug hole until the o-ring on the adapter seats firmly (do not use a wrench to tighten).
4. Ensure the spark plug is grounded to the cylinder head or is insulated in a way that will prevent an electric shock hazard.
5. Crank the engine over using the pull cord (or starter if electric) a minimum of 5 revolutions. This will allow the cylinder to build sufficient compression to be measured.
6. Refer to the manufacturer's data to determine the correct reading

Using the Pressure Hold Adapter

The **Craftsman** Professional Compression Tester comes with a pressure hold adapter. This adapter is used to perform valve seal replacement on an engine without removing the cylinder head(s). To use the adapter:

1. Remove the spark plug from the desired cylinder.
2. Select the appropriate extension hose that will fit the spark plug hole.
3. Using the valve core tool (from the field service kit included), remove the valve core from the end of the hose and lay it aside.
4. Thread the extension hose into the spark plug hole until the o-ring seats; do not use pliers or a wrench to tighten.

5. Attach the Air Hold Adapter to the extension hose.

6. Attach a shop air hose to the Air Hold Adapter, this will maintain air pressure in the cylinder to hold the valves closed while performing repairs. (It may be necessary to rotate the engine until all valve are closed and air is holding in the cylinder)

Note: The air hold quick connector does not come with a compressed air line fitting to adapt to your air source. This will have to be purchased separately to fit your system.

For answers to technical questions, or to order replacement parts, call or fax:

Phone: (314) 679-4200 Ext. 4782

Fax: (314) 679-HELP (4357)

Full One Year Warranty

If this Craftsman® Compression Test Kit is defective in material or workmanship within one (1) year from the date of purchase, return it to your nearest Sears store in the United States, and it will be replaced free of charge.

Sear, Roebuck and Co., Dept. 817WA,
Hoffman Estates, IL 60179

CAUTION

TO AVOID PERSONAL INJURY AND/OR VEHICLE DAMAGE:

While some precautions are specified in this manual, and should be noted to avoid personal injury or vehicle damage, it is not possible for these cautions to cover all conceivable ways in which service or testing might be done, or all possible hazardous consequences of each way, nor could Lincoln possibly know or investigate all such ways. It is therefore the responsibility of anyone using this manual or any other Mityvac product, to satisfy him or herself completely that neither personal safety nor vehicle safety will be jeopardized by the service methods selected. Any such injury or damage is entirely the user's responsibility. This device is not to be used in any manner on the human body.

CRAFTSMAN®

MODEL 47089
COMPRESSION TEST KIT

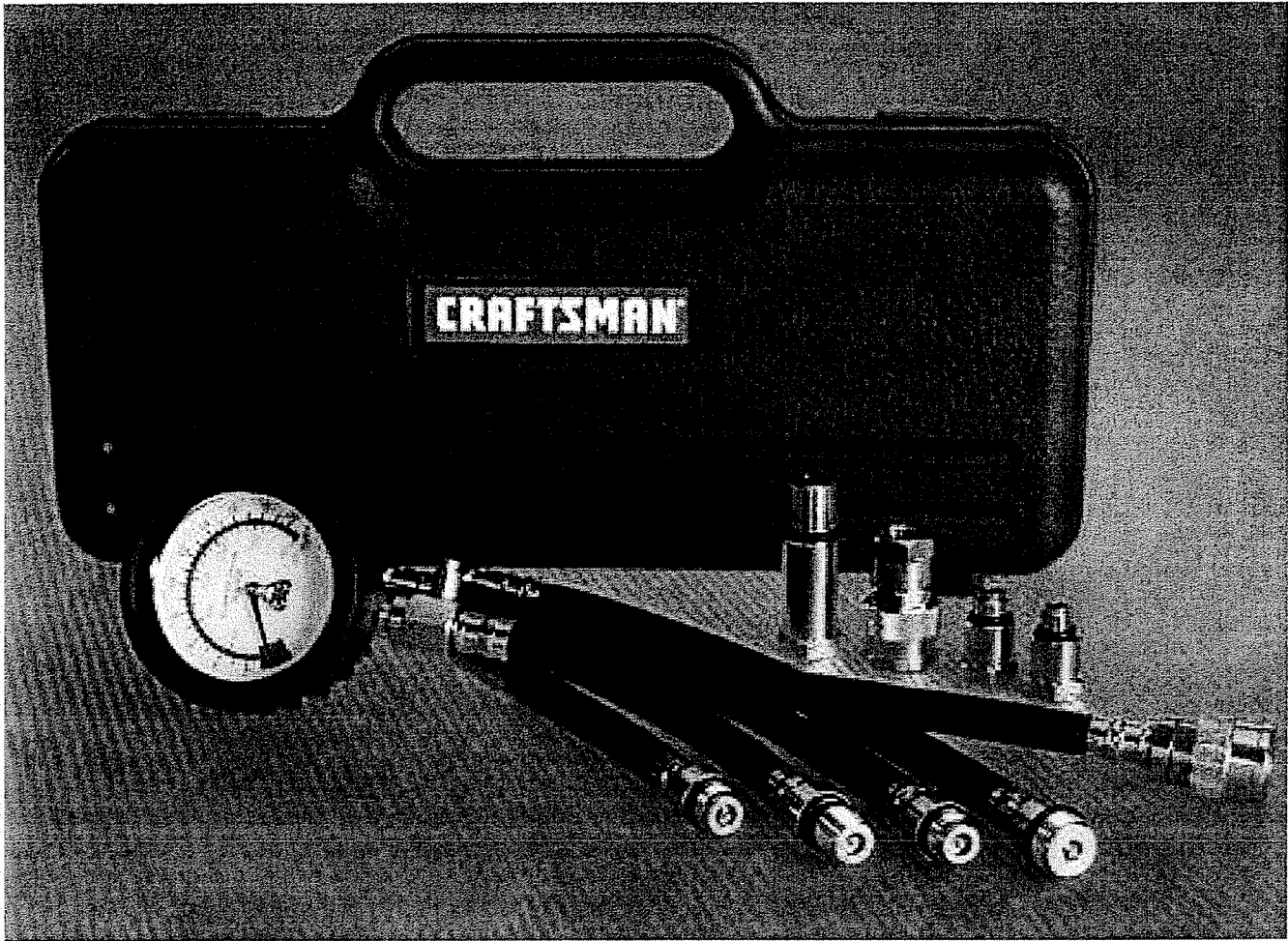

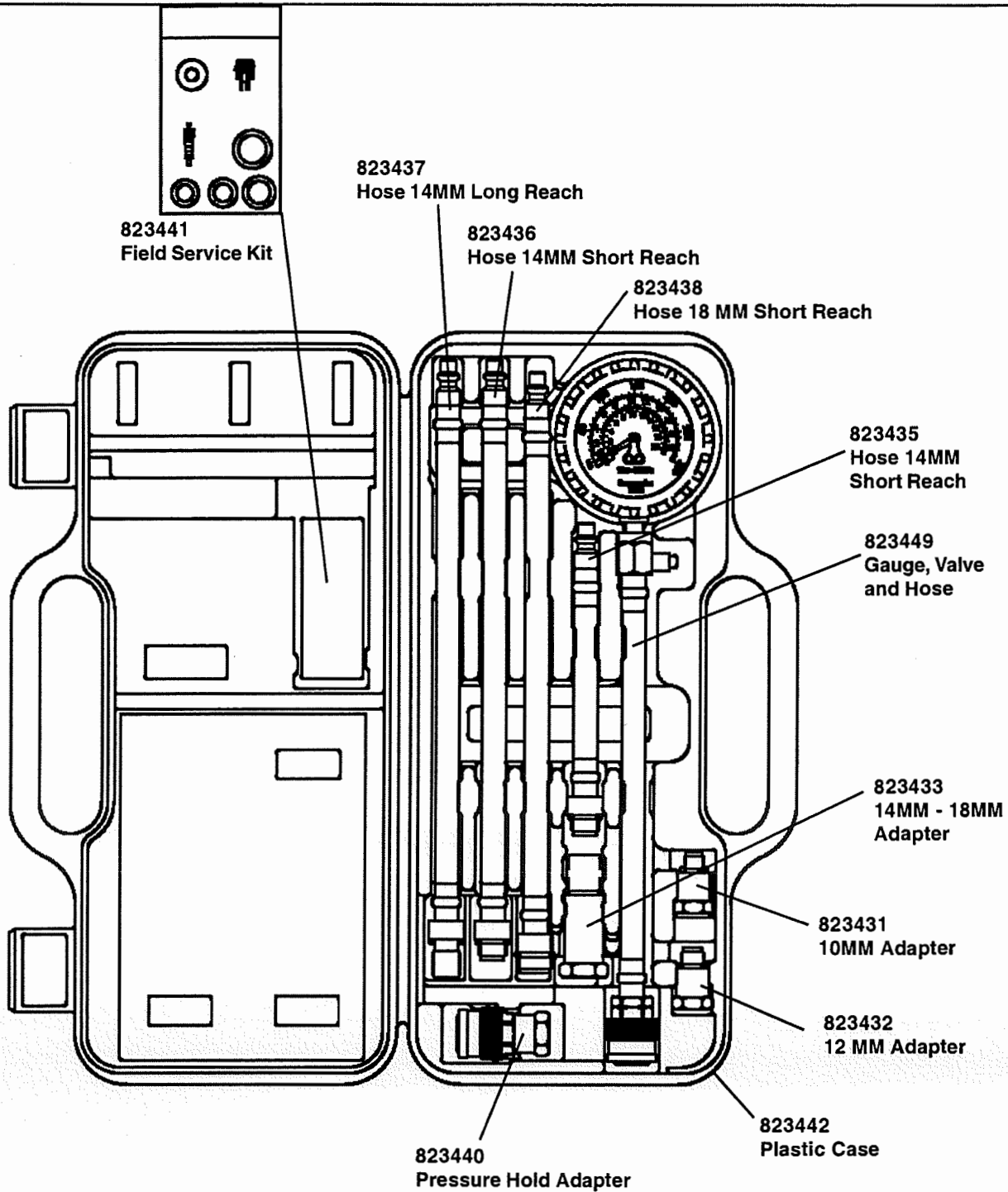

Part No.	Description	Part No.	Description
823431	10MM Adapter	823438	Hose Long reach 18MM x 11.625
823432	12MM Adapter	823440	Pressure Hold Adapter
823433	14MM Female - 18MM Male Adapter	823441	Field Service Kit
823435	Hose Short Reach 14MM x 6.05	823442	Case
823436	Hose Short Reach 14MM x 11.625	823448*	Gauge
823437	Hose Long Reach 14MM x 11.951	823449	Gauge Assembly

* Not Shown

Always read instructions carefully prior to use.

Included in this Kit

- Heavy duty 2 3/4" (70 mm) gauge with high impact lens, rubber boot, and three (3) scales of measure (psi, kg/cm², bar), attached to 10" (250 mm) hose and quick release coupler
- Four (4) extension hoses:
 - 6 1/2" (165 mm) long x 14 mm thread, short
 - 12" (305 mm) long x 14 mm thread, short
 - 12" (305 mm) long x 14 mm thread, long
 - 12" (305 mm) long x 18 mm thread, short
- One (1) adapter: 14 mm thread, short x 18 mm thread, long
- Two (2) small engine adapters
 - 10 mm thread
 - 12 mm thread
- One (1) quick release air hold adapter
- Custom blow-molded case
- Field service kit

Applications

The **Craftsman Professional Compression Test Kit** can perform dry or wet compression tests to determine the amount of pressure produced in the cylinder of an engine. It can also be used as a tool for pressurizing an engine cylinder to hold the valves closed while performing repairs.

How to Perform a Compression Test

Precautions & Diagnostic Notes:

WARNING: DO NOT use the ignition switch during the compression test on fuel-injected vehicles. Use of a remote starter switch to crank the engine is recommended. Fuel injectors on many late model vehicles are triggered by the ignition switch during the cranking mode, this could result in a fire hazard or contamination of the engine's oil with fuel.

Always use eye protection when performing compression tests.

An engine in good operating condition will produce a certain amount of pressure in each cylinder. Normally, the cylinders should be within 10 percentage points of one another and within the manufacturer's specifications. The pressure should rise smoothly on each stroke of the engine, until it reaches a peak.

If the pressure reading fails to rise, or it remains the same for several strokes of the engine and begins to rise, the likely cause of the problem is a sticking valve.

If two adjacent cylinders show pressure readings of 20 or more pounds below the other cylinder readings, suspect a blown head gasket.

If a cylinder shows a pressure reading of 15 or more pounds higher than the other cylinders, the probable cause is carbon build-up inside the cylinder.

The **Craftsman Professional Compression Test Kit** can perform two tests: the dry compression test and the wet compression test. The result of performing these tests will provide an indication of the condition of the piston rings, the cylinders, and valve-train.

Dry Compression Test Procedures:

1. Refer to the appropriate service manual for the compression specifications specific to the engine you are testing.
2. Start engine and allow engine to run until it reaches normal operating temperature (usually about 15 minutes.) Turn engine OFF.
3. Install an auxiliary starter switch in the starting circuit.
4. While wearing eye protection, use compressed air to carefully remove dirt and debris from the area around the spark plugs.
5. Remove spark plugs one at a time, marking the number of the cylinder they were removed from, and place them on a clean flat surface. This will aid you in identifying problem cylinders by allowing the comparison of spark plug appearance to the compression level of a given cylinder.

NOTE: When testing engines with two spark plugs per cylinder, it is only necessary to remove the spark plugs located on the exhaust side.

6. On vehicles with standard distributors, disconnect the coil wire (high tension lead) from the distributor cap and secure it to a suitable ground, or disable the ignition by disconnecting the positive (BAT) terminal from the ignition coil.
7. On vehicles with a distributorless ignition (DIS), disable the ignition system by removing the electronic ignition (control) module fuse, or disconnect the crank angle sensor.

NOTE: Refer to the appropriate service manual to determine which fuse or component to temporarily remove or disconnect.

8. Remove air cleaner from carburetor or throttle body and secure throttle linkage in wide-open throttle (WOT) position.

NOTE: NEVER place anything inside the throttle body; internal damage to the engine could result. On vehicles equipped with port fuel injection, remove throttle linkage covers (as necessary) and secure throttle linkage in the wide-open throttle (WOT) position.

9. Crank engine several times to ensure removal of any foreign matter that may have fallen into the cylinders during preparation for test.
10. Select the appropriate adapter fitting (14mm, 18mm short reach or 14mm, 18mm long-reach), and thread adapter into spark plug hole of cylinder head.
11. Connect the appropriate test hose or adapter to the gauge assembly.
12. Crank the engine at least five compression strokes or until the pressure reading stops increasing on gauge.
13. Read the pressure level on the gauge and record the reading along with the cylinder number being tested. **Example: #1-150 psi, #2-145 psi, etc.**
14. Repeat this test on each cylinder. If any of the cylinder readings are found to be low or uneven, perform wet compression test.

15. When compression test is complete, return the spark plugs to their respective cylinders and the throttle and ignition components to their normal positions.

Wet Compression Test Procedure

CAUTION: DO NOT perform the wet compression test on any diesel engine. The higher compression in a diesel engine may cause engine damage or injury to the technician.

The wet compression is a way to remove the influence of the piston rings, pistons and cylinders from the compression test. After completing the dry compression test, squirt approximately one teaspoon of engine oil into the spark plug holes and crank the engine several times to seal the piston rings. Repeat the dry compression test outlined above. **NOTE: If the readings during the wet compression test are greater, then air is leaking around worn or damaged piston rings. If the reading is approximately the same for both wet and dry tests then the valves, valve lifters or the camshaft lobes are worn. Any low reading of cylinder compression indicates worn or damaged parts.**

Small Engine Compression Testing

The **Craftsman** Professional Compression Test Kit has two (2) adapters, 10mm and 12mm, that allow it to be used on small engines found in lawn mowers, chain saws and line trimmers. To use these adapters:

1. Disconnect the spark plug wire and remove the spark plug.
2. Thread the appropriate size adapter onto the compression tester main hose end until the o-ring seats (do not use a wrench to tighten).
3. Thread the assembly into the cylinder spark plug hole until the o-ring on the adapter seats firmly (do not use a wrench to tighten).
4. Ensure the spark plug is grounded to the cylinder head or is insulated in a way that will prevent an electric shock hazard.
5. Crank the engine over using the pull cord (or starter if electric) a minimum of 5 revolutions. This will allow the cylinder to build sufficient compression to be measured.
6. Refer to the manufacturer's data to determine the correct reading

Using the Pressure Hold Adapter

The **Craftsman** Professional Compression Tester comes with a pressure hold adapter. This adapter is used to perform valve seal replacement on an engine without removing the cylinder head(s). To use the adapter:

1. Remove the spark plug from the desired cylinder.
2. Select the appropriate extension hose that will fit the spark plug hole.
3. Using the valve core tool (from the field service kit included), remove the valve core from the end of the hose and lay it aside.
4. Thread the extension hose into the spark plug hole until the o-ring seats; do not use pliers or a wrench to tighten.

5. Attach the Air Hold Adapter to the extension hose.
6. Attach a shop air hose to the Air Hold Adapter, this will maintain air pressure in the cylinder to hold the valves closed while performing repairs. (It may be necessary to rotate the engine until all valve are closed and air is holding in the cylinder)

Note: The air hold quick connector does not come with a compressed air line fitting to adapt to your air source. This will have to be purchased separately to fit your system.

For answers to technical questions, or to order replacement parts, call or fax:

Phone: (314) 679-4200 Ext. 4782
Fax: (314) 679-HELP (4357)

Full One Year Warranty

If this Craftsman® Compression Test Kit is defective in material or workmanship within one (1) year from the date of purchase, return it to your nearest Sears store in the United States, and it will be replaced free of charge.

Sear, Roebuck and Co., Dept. 817WA,
Hoffman Estates, IL 60179

CAUTION

TO AVOID PERSONAL INJURY AND/OR VEHICLE DAMAGE:

While some precautions are specified in this manual, and should be noted to avoid personal injury or vehicle damage, it is not possible for these cautions to cover all conceivable ways in which service or testing might be done, or all possible hazardous consequences of each way, nor could Lincoln possibly know or investigate all such ways. It is therefore the responsibility of anyone using this manual or any other Mityvac product, to satisfy him or herself completely that neither personal safety nor vehicle safety will be jeopardized by the service methods selected. Any such injury or damage is entirely the user's responsibility. This device is not to be used in any manner on the human body.